

PREMIUM 5-DRAWER WORKSTATION

Ref. **076143** (without tools)
Ref. **080119** (with tools)

Powder-coated steel design for **high resistance to wear and tear.**

Lid with 2 gas struts for smooth operation.

Practical handle

Large lockable compartment* for tools and bulky items.

Bottle support, ideal for storing aerosol cans, cleaning products, spray cans, etc.

Centralised locking system with round key for the lid and drawers.

5 drawers* with ball-bearing runners.

1 large-volume tray* with anti-drop edges.

Highly manoeuvrable: 4 heavy-duty castors, 2 fixed and 2 swivel with locking brake.



*Non-slip matting in all drawers, boxes and shelves.

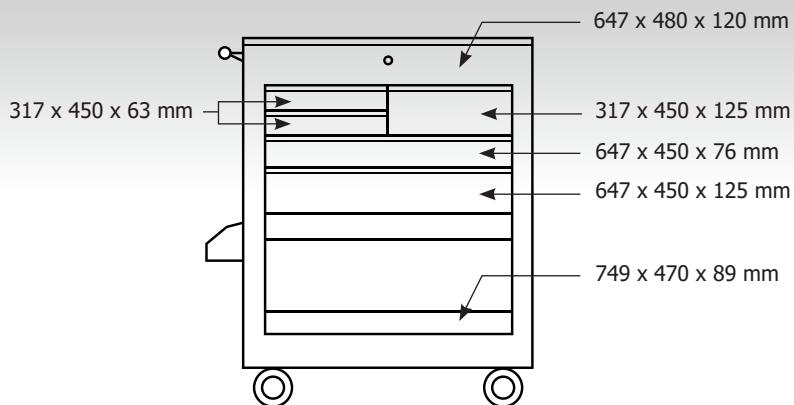

Weight capacity	320 kg
Dimensions including handle	867 x 560 x 1050 mm
Weight when empty	64 kg
Round keys supplied	x4